“Open building architecture”, a concept founded by N. John Habraken, is an approach to design that increases the variety, flexibility and quality of space, ensures the idea of choice and personalization in living for the inhabitant (Nascimento 2013). These ideas of choice and personalized living are critical, largely in part to the inherent emotional connection people carry with the physical environment (Marcus 2006). The notion of applying a singular scheme to the living needs of the greater whole can no longer be an acceptable means of designing. In the sector of healthcare (hospitals, nursing homes, etc.) this similar quality of homogenized living conditions, void of any personal identity, has come to be all too familiar (Swensson 2012). Through the implementation of open building architecture, one can break free of the cookie cutter approach to design and begin to disentangle the specific parts of a building, thus enabling broader consumer choice in laying out, equipping, and furnishing space (Kendall 2002). In regards to inter-generational living, the aspect of adapting to changing needs over time is critical in order to adequately serve the needs of our aging population, and by means of open building architecture, one can begin to focus design on the user/inhabitant. The users, then, become recognized as the decision making agents, and in turn the architecture becomes more suitable to the individual’s needs (Nascimento 2013). Thus, the purpose of this project is to investigate the potential benefits of open building architecture in the design of inter-generational living, with the goal being to sustain choice, personalization, and independence for its inhabitants.



ian kilpatrick

Inter-Generational Living: Open Building
Architecture and the Importance of
Choice & Independence





redefining open building

“One of the fundamental objectives of Open Building is to restore the ‘natural relation’ between building form and the inhabitants. Design tends to assume that the inhabitants’ lives are generic. Buildings are so fixed in their aesthetics and functions that people must adapt to buildings, because buildings have not been made to be adaptable to the people who live in them.”

N. John Habraken

Introduction

In a society plagued with seemingly more and more health problems, the notion of health and wellness is all too prevalent. As human beings, people look in all places for holistic health and wellness, whether by means of a vacation to a relaxing resort, psychological therapy, or even something as simple as a walk in the park on a nice day. Who is to say though, that the home environment should be excluded from this list? Home is the most central place to people. It is the respite from a busy day, the expression of one’s self. Home is where people learn to be themselves, to live, and love (Marcus 2006). The built environment should enhance users’ wellbeing, not undermine it, and home is no

exception. Currently, the model for housing is less concerned with enhancing user wellbeing unless specifically designed for a person. As it stands today in America, developers have begun creating housing that is very much becoming a homogenized experience; a series of cookie cutter neighborhoods and identical apartment complexes doing little to nothing other than perpetuating the notions of placelessness and suburbia (Swensson 2012).

This idea of applying a singular design solution to housing leaves not only a disheartening image of the approach to residential design, but also a lack of personal choice and flexibility in living arrangements. Today



more than ever family units are being redefined, and with demographics changing as they are, housing needs to consider models for more than the typical single-family. The demand for housing designed in a way that can accommodate anything from the single person living alone to a household of multiple generations (i.e. inter-generational living) is only going to grow (Health & Aging

2011). Open Building, a concept established by N. John Habraken in the late 1960's that looks at creating adaptable spaces that change with the user, is the perfect means by which to redefine how designers think about housing.

Given the notions of choice and personalization, the underlying concepts of N. John Habraken in Open Building design, adaptability and customization of space can help encourage a healthier approach to housing design. Furthermore, the employment of said concepts in an inter-generational living community can aid in promoting alternative living situations (as seen in an inter-generational household), aging-in-place, and creating environments centered around the user as the decision making agent.

Healing Space in Architecture

In his book *Healing Places*, Wilbert Gesler looks at the multidimensional character of how the built environment affects physical, mental, spiritual, emotional, and social areas of health and wellbeing. According to Gesler, a healing environment, or “healing sense of place” successfully demonstrates four different environmental “dimensions”: natural, social, symbolic, and built (Gesler 2003).

Nature has historically been considered to have healing powers. In terms of a biological cycle, nature is a regenerative force, aiding in our basic survival by providing food and oxygen. By

Gesler's standards, the natural dimension is seen as a refuge for healing, one that humans have developed an affinity and feel comforted by. The built environment concerns the environment which humans have created. The social environment includes the social settings in which people live their lives, which is to say where a person feels a connection to society or a community of common beliefs, values, ideals, etc. An inherent connectedness between these three dimensions exists, and the symbolic environment Gesler refers to is no exception. In terms of healing, symbols in the environment can be something as simple as objects around a person that have meaning and importance. It can also refer to mediation between biophysical and sociocultural worlds, tying back to commonly held values, meanings, beliefs, etc. Finally Gesler looks to the dimension of the built environment, quite possibly the most relevant in terms of a concrete architectural idea. Much of the argument of healing in the built environment exists on the premise that what people experience in their

surroundings has a direct effect on the moods and emotions of humans (Gesler 2003).

Clare Cooper Marcus discusses the idea of healing space in regards to the home environment specifically. People carry and inherent emotional connection to almost every physical environment, the home being no exception. Whether good or bad, this connection exists differently for everyone, and thus means that the ideas of “home” and “healing” differ for everyone (Marcus 2006). As a result, housing needs to be considered in a more independent fashion than it currently exists today. In regards to healing environments, design should center on what the user needs and finds healing, and be implemented accordingly. Home is in essence a center (of sorts) in every human's life. Healing can and should exist in all aspects of the built world, but one of the most important places is on the level of home. It should be where people are wholly themselves, because the needs of one person will rarely, if ever, be the same as others (especially in terms of healing environments).

Baby Boomer Generation

Baby Boomers, the generation of people born between 1946 and 1964, are those now faced with aging and having to address what to do in the latter portion of life. In America alone, 77 million people are considered to be baby boomers, an unprecedented number of aging people. By the year 2015, it is expected that 45% of the U.S. population will be aged 50+ (Frey 2010). The need to address this drastic

change in the aging population will quickly become more pertinent than ever before.

It should be noted that the boomer generation has often been characterized as the “rule breakers” of today, having developed an ethos that stresses the pursuit of personal fulfillment while also growing up rejecting traditional social roles

and redefining the norm (Greenblatt 2007). In turn, it can be generally put that the baby boomers carry an attitude toward change for their personal betterment.

Given the boomer attitudes outlined above, it could be assumed that many of the aging boomers will quickly reject living arrangements and housing for the “elderly” as they stand today, and work to redefine what it means to age, and how one might do that. This attitude toward change is perfect for a new type of housing, and new approach to aging: inter-generational living.



Inter-Generational Living

Already prevalent and deeply rooted in parts of the world such as Europe, inter-generational living looks to an alternative idea of housing, aiming to create an environment that incorporates both young and older generations living together in an apartment style setting. The intent behind an inter-generational community is obviously to promote a sense of community and socialization across at least three generations, but also to avoid the drawbacks a senior living alone might face in a nursing home facility living exclusively among other seniors (Building Livable Communities 2014).

Within a single household, inter-generational living arrangements are becoming more and

more ubiquitous. As life spans of humans continue to increase, many families are now faced with the issues arising out of what is referred to as the “sandwich generation”, or in other words a household that might include the boomers, their children, as well as their parents (3 generations living together). The idea of inter-generational living on a household level, let alone a community level is quickly going to become a common reality (Goyer 2014).

As the model exists today, inter-generational living holds more benefits than faults. First and foremost is the bridging of a generational gap between older and younger people that only seems to be worsening. By integrating seniors and youth into a cohesive environment, not only do seniors remain an integral part of society (in lieu of being cast away into nursing homes), but also have the ability to continue learning from younger generations, and vice versa. In regards to learning from one and other,

younger generations begin to learn to have a healthier attitude toward again, as well a certain amount of stability that can be lent by someone older and more experienced (Building Livable Communities 2014). It seems readily apparent that through inter-generational living, a supportive family of sorts can exist and better the lives of younger and older generations. The key, however, is creating a community with a willingness of residents to live in the sort of arrangement proposed, and successfully generate a supportive community.

The necessity for inter-generational living is quite apparent. With the growing number of aging baby boomers, and the inability for inter-generational groups (not necessarily blood related) to find housing that supports this type of lifestyle, it is clear a new innovative type of housing needs to become a part of the picture, and that is what inter-generational living has to offer.

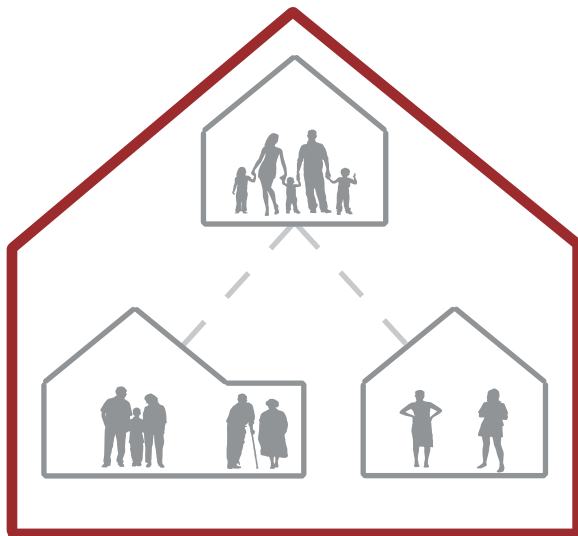

Atypical family structures in an inter-generational community



John Habraken

Open Building

Originally established in the late 1960's by N. John Habraken (and later furthered by Stephen Kendall), Open Building is an alternative approach to residential design, financing, construction, fit-out, and management that investigates the potential for modification and adaptability. The driving force behind Habraken's investigation into Open Building is from a lack of adaptability existing in housing, and recognition that not all people live the same. Open Building is already prevalent in the way retail spaces are designed (support and infill), and is works as an ideal model to translate into housing. (Kendall 2000). Closely linked to the idea of support and infill, Open

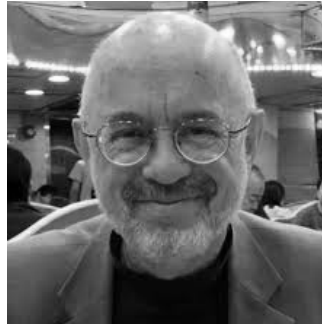

Stephen Kendall

Building operates on a similar set of guidelines recognizing that certain layers of intervention exist within a building. Habraken's approach looks to "disentangle the various parts" of a building (structure, envelope, infill, etc.) and recognize that these various parts have different lifespans and will be changing over time. Interface between systems within the building should allow for the replacement of one with another performing the same task, with little interruption to the rest of the building. To Habraken, the environment is an ongoing, never ending design (Kendall 2014). Stephen Kendall raises the question "How do we design the built

environment to support both stability - in respect to long term community interests - and change - in respect to individual preferences?" A central and key point to Open Building is this notion that design should be (and in terms of Open Building is) centered on the needs of the user. The built environment is not something that exists for professionals, but rather professionals exist for it (Nascimento 2012). By means of centering design around what a user specifically needs, they become a decision making agent, and an indispensable power for the existence of the built environment. In his concept of Open Building, Habraken outlines a set of guidelines that are the central guiding principles for any project in Open

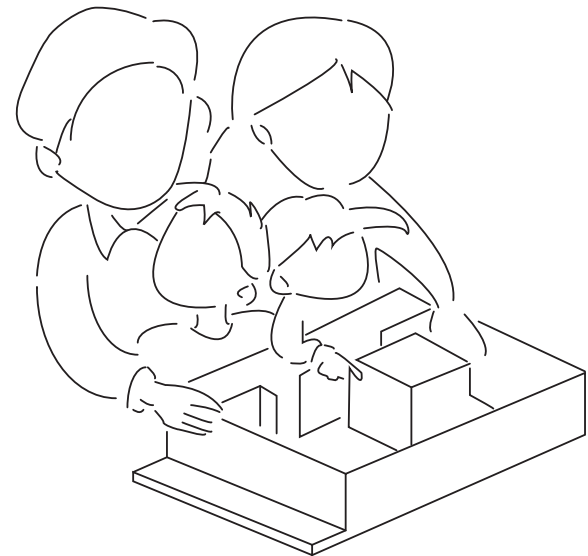

Open building's focus on user-centered design

Building First and foremost is the idea of distinct levels of intervention (as discussed earlier), as well as this notion of user centered design. Building upon that is the idea that design is a process with multiple participants, including a number of different kinds of professionals. As stated earlier, the idea that the interface between systems allows for the replacement of one with another is critical in Open Building, as well as the awareness that the built environment is in constant transformation. Finally, is a recognition that while the built environment is always changing, various parts of it are going to need to change at different times. This is crucial to understanding and implementing Open Building (Habraken 1979).

Stephen Kendall expanded on Habraken's work by beginning to outline the levels of control in which a building operates. Going back to Habraken's idea of recognizing the various levels of a building and their different lifespans, Kendall chooses to specifically break them down from macro to micro level as: site, skin, structure, services, space, and "stuff". The idea here is that each level acts independently within the greater whole, and that the level such as structure might have a lifespan of 150 years, while the space's lifespan may only be 20 years. By creating levels of control, the designer and later tenants of the space are able to adapt those levels with shorter lifespans without disturbing other parts of the building (Kendall 2014).

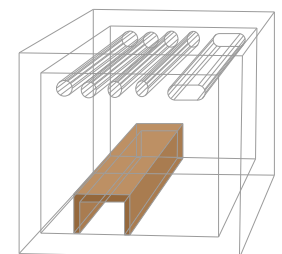
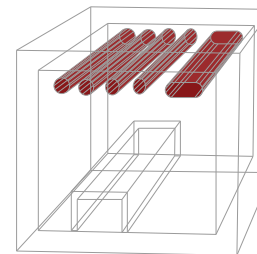
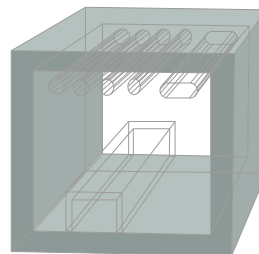
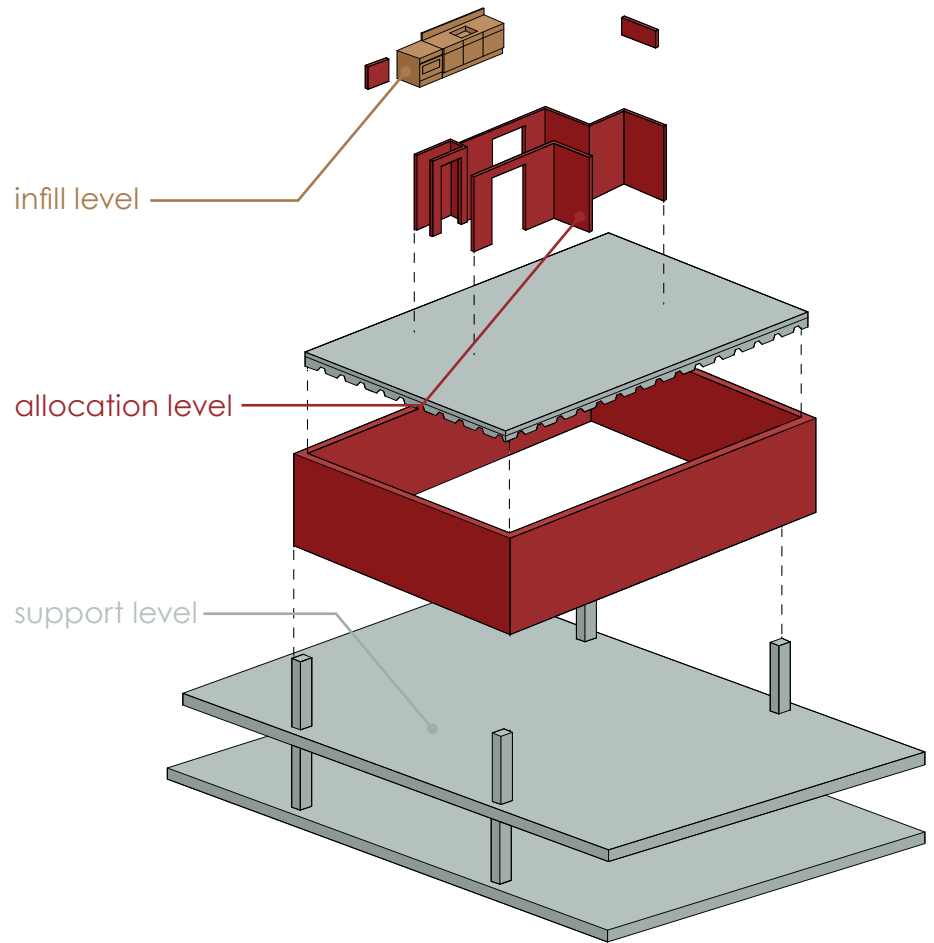

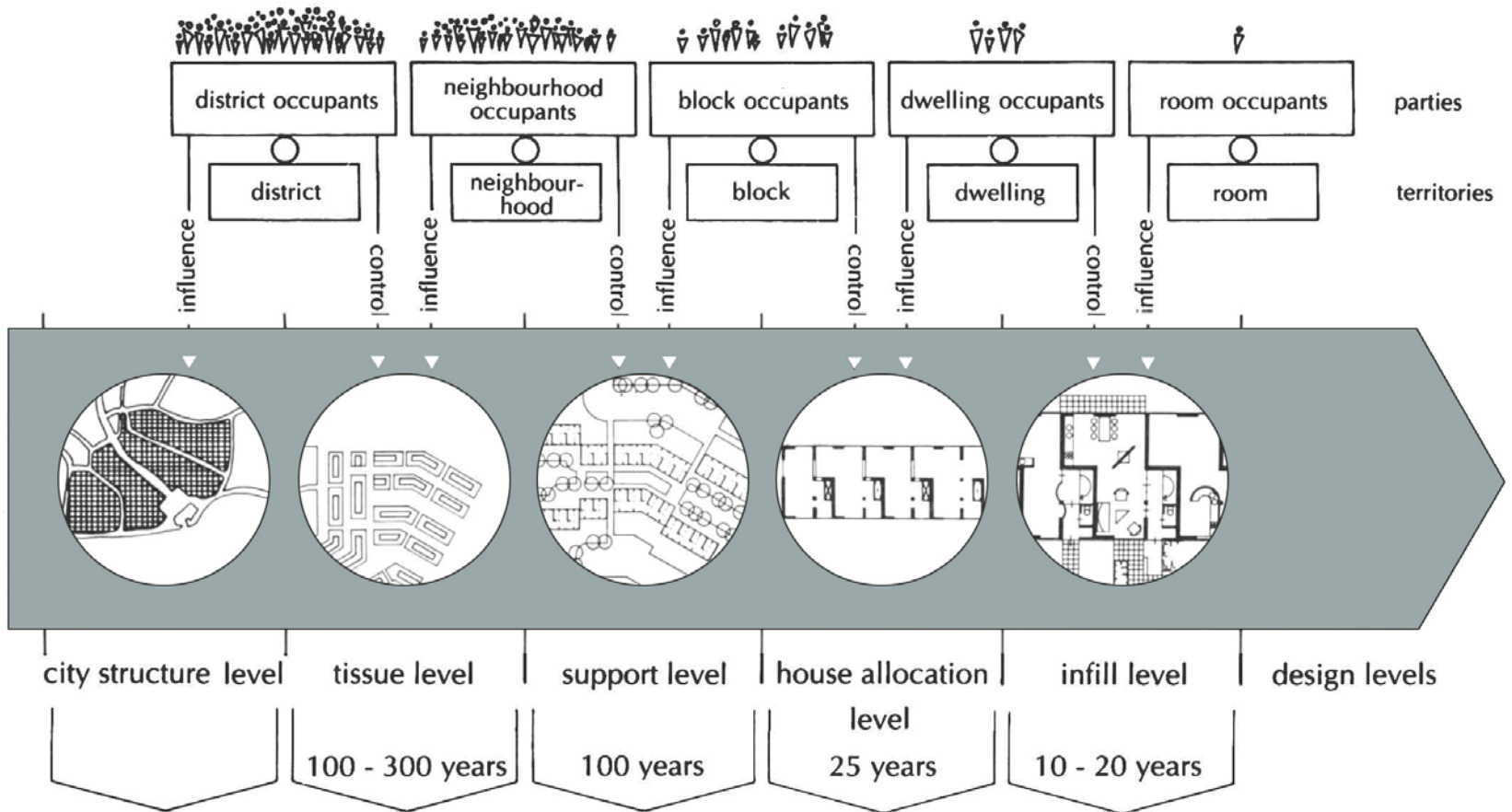

Levels of control defined by Habraken

Open Building: Promoting Inter-Generational Households

As the reality of the sandwich generation becomes more prevalent, households are going to have to accommodate to changing needs accordingly. Currently America designs a majority of urban apartment housing with the single-family unit in mind, or the single/married person, and leaves little room for change within these predetermined conditions (Gross 2008). For families living in an inter-generational setting, that is to say with more than two generations in a single home, this may not be the ideal situation. Urban housing has generally offered few options for living arrangements, thus people seeking an inter-generational household have become accustomed to making something less than ideal work.

Open Building has the opportunity to allow greater flexibility and change over time within the apartment, and in turn would allow for a

plethora of living arrangements (whether one chooses to live with multiple generations of their family, or a roommate situation). For example, as it stands today, a family looking to “incorporate” grandma into the household might think it ideal to give her a separate space only for her. A typical apartment one might find is not necessarily conducive to this living arrangement, and is even less so to potentially changing the apartment layout, structure, etc. By means of Open Building, users would have the opportunity to define the level of interaction or separation they want between generations

in a single household. Therefore, Open Building offers the opportunity on a localized, individual unit scale, to allow almost any inter-generational living situation to occur. Without predetermining layouts in the manner in which designers often do, the user can create a space ideally conducive to their own personal living situation.







single young professional



-separate spaces
allocated rather than
studio style apartment

-office space emphasized
over living

-circular movement
throughout

-storage built in/space
dividing element

-ability to change office to
bedroom given the need

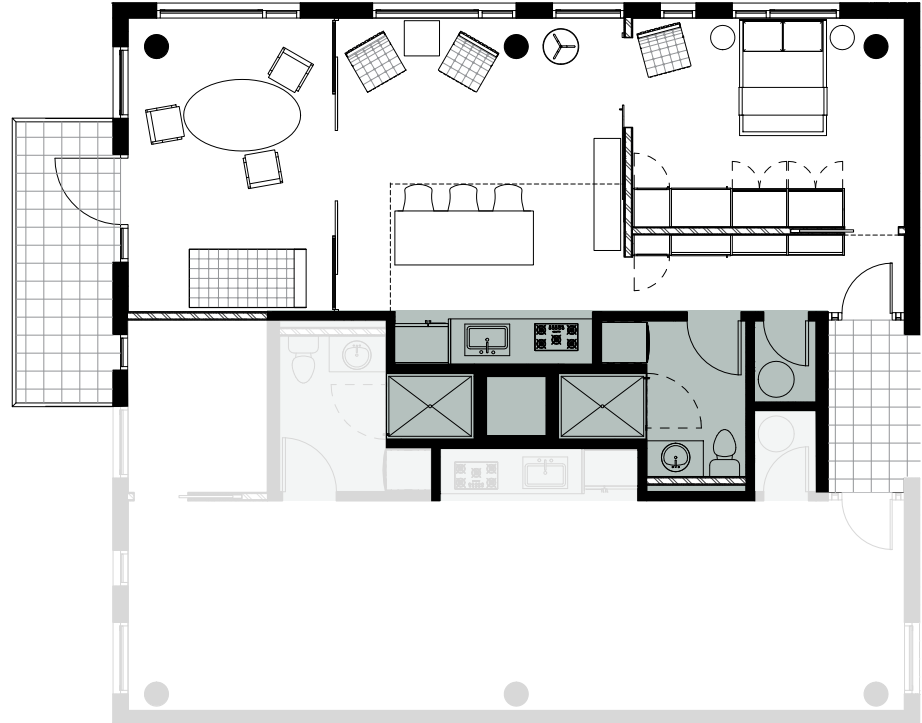



friends & roommates



-emphasis on individual bedrooms

-shared space centrally located

-circular movement throughout

-joker space accommodates small office

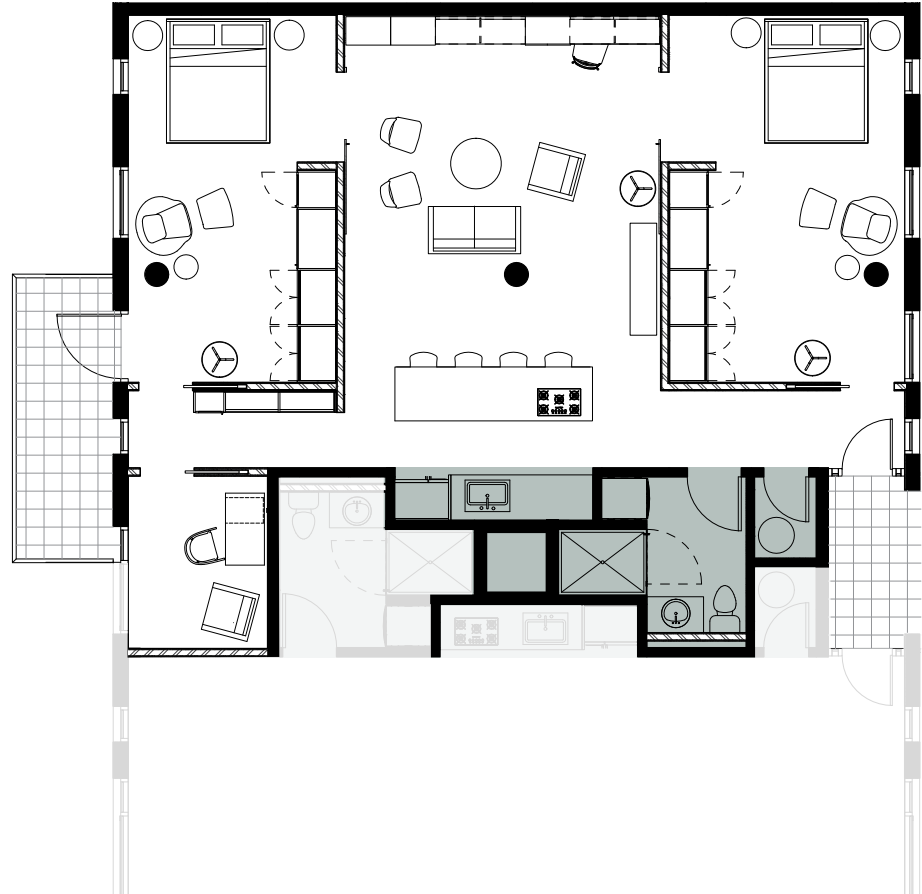



the inter-gen family unit



-emphasis on individual expansion

-addition of grandparent "suite"

-circular movement throughout

-joker space accommodates small office & connection to caretaker

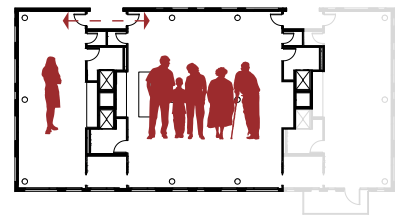
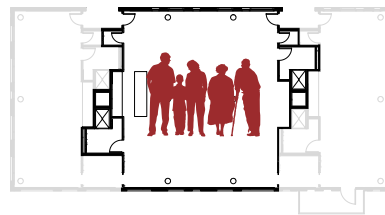
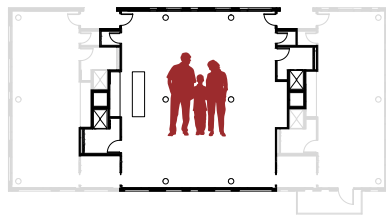



parents & child

Open Building: Aging-In-Place

In this day and age, more and more Americans 45 and older want to continue living in a familiar environment. The idea of aging-in-place, or in other words being able to remain in one's home throughout the duration of one's life, is not a new concept. People have always, and will always, prefer remaining in their own homes, their own comfort levels, as opposed to being uprooted and placed elsewhere to live out the remainder of their life, such as an institution (Wylde 1994).

The way in which homes are designed today are not meant to change with people. For instance, the typical suburban home is designed with a fully capable person (with no handicap or physical ailments) as the future user. Given that the majority of humans are able bodied for a good duration of their life, what is to come of them in their homes when they do have some sort of mobility issue? Various floor levels can make some rooms less accessible, upper cabinets harder to reach, doorways more difficult to get through. When Universal Design is employed in residential design, many of these issues become lessened, but not all. As stated earlier, in the majority of housing in America, the environment is not readily able to change with the user, as their needs change over time.

Open Building's central focus on creating adaptable spaces is a truly viable option for promoting aging-in-place. When the physical environment is designed in a manner that

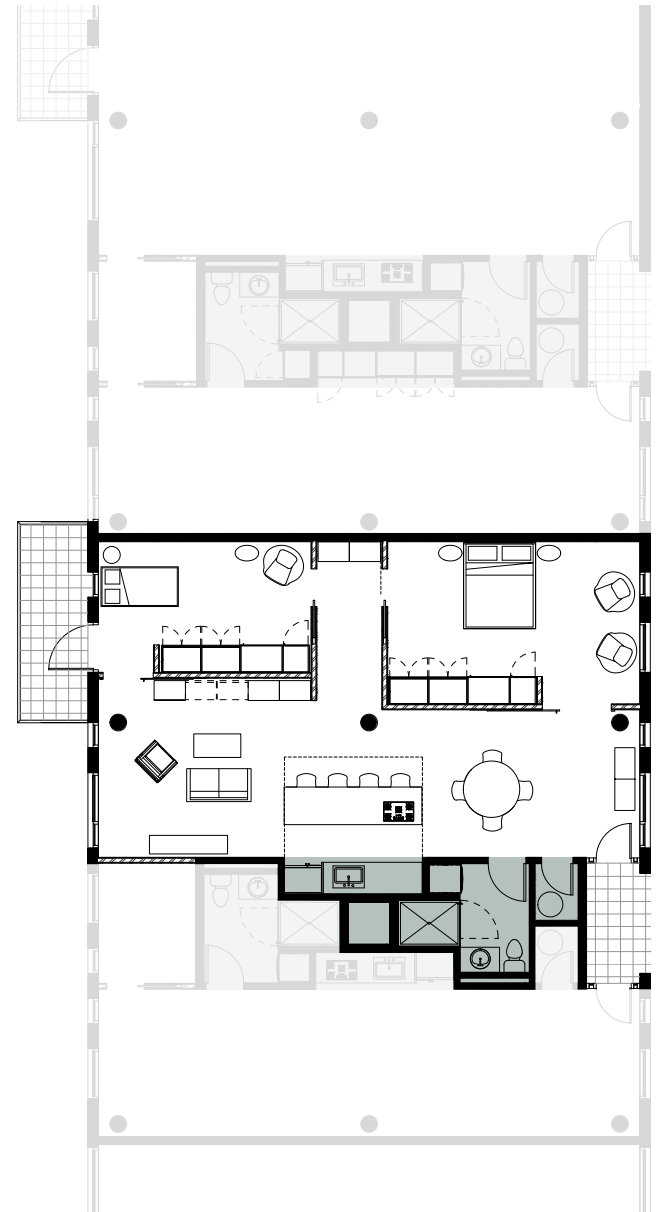



addition of grandparents

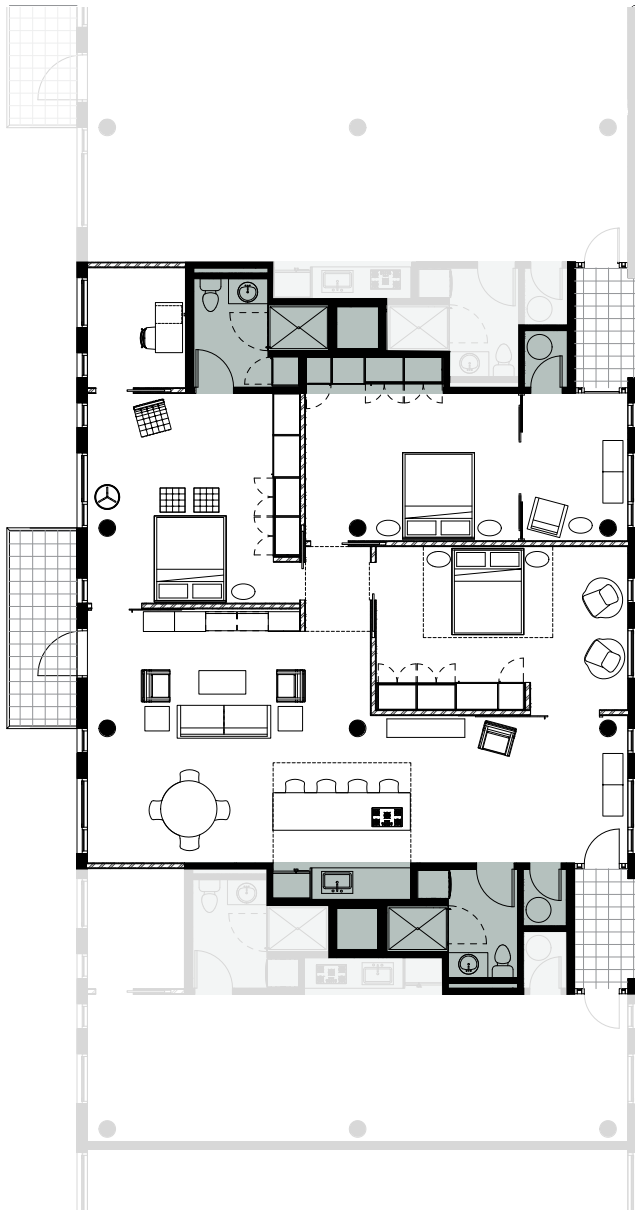

caretaker

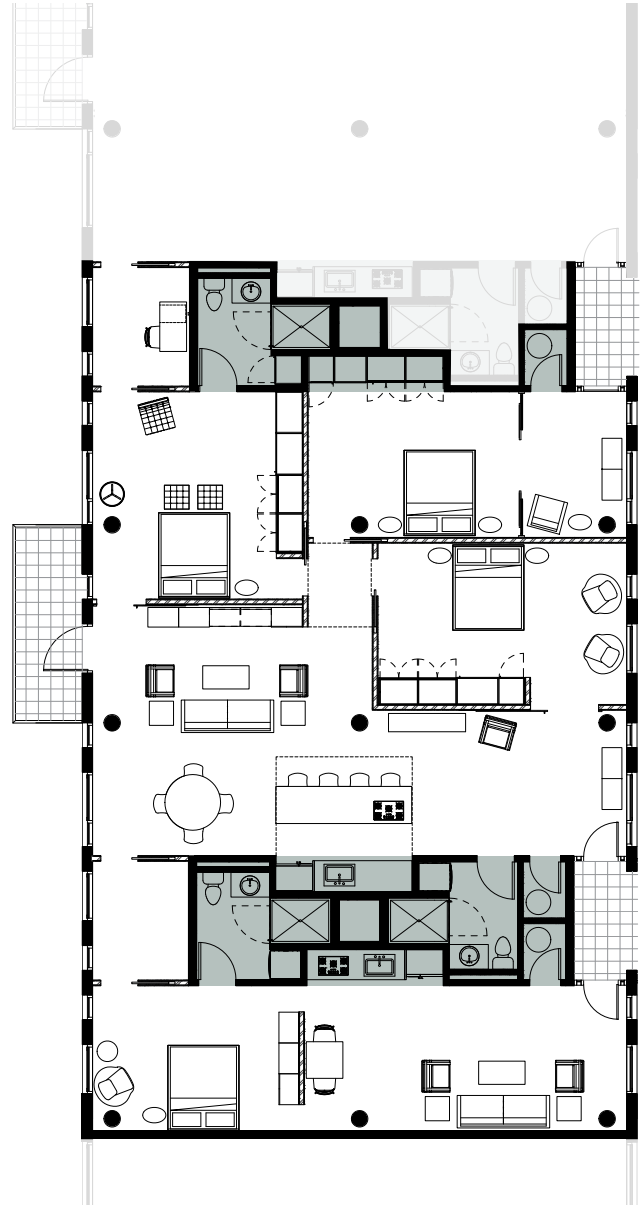

is capable of changing as people need it to, the notion of aging in a singular place does not become a cumbersome issue. Relevant in both changing mobility needs, but also simply changing lifestyle needs, Open Building has the capability of creating comfortable, safe, and socially supportive environments people can be happy in for a good majority of their life (if they so choose).

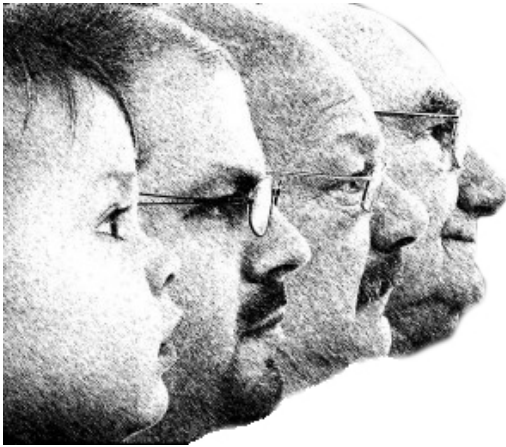

Open Building: Healing Environments

As stated earlier the meaning of home differs for everyone. The same holds true for creating healing spaces, particularly in the home environment. Personal preferences are a reality of everyday life, and it never fails that people are going to react differently to a space and have a diverse array of emotional connections to their physical environment. The home, considered to be most people's home base, the center which they return to

every day, should be a healing environment, if not the most healing environment in their life. Designing for such an environment puts a considerable emphasis on the notions of choice and personalization.

By utilizing Open Building as a means for housing design, the users have the opportunity to become the decision making agent, and in turn can choose how their living environment looks, feels, and is arranged. With the option to have some amount of choice in how personal space is designed, the users are able to create and enjoy something that is truly

their own. By creating positive emotional connections, as Clare Cooper Marcus would call them, a true sense of healing can occur on a daily basis in the very environment central to people's lives.

One might even consider the implications customizable healing spaces has on a sense of community. By allowing the opportunity to create personalized home environments, users will subsequently take greater pride in their home, and often times this shared value among residents can serve as a basis for a greater sense of community.



Client consultation with local architect



Rear walkways to access apartments

Conclusion

Utilizing Open Building principles in an inter-generational community offer opportunities to successfully create building types fostering alternative living situations,

aging-in-place, and creating healing environments. In a world where much of the housing has become homogenized and void of personal identity, it is critical that designers recognize

a disregard to individual need is no longer an option. Open Building not only succeeds in changing the way housing is designed, but furthermore creates a successful model for a new type of housing that people want to live in.

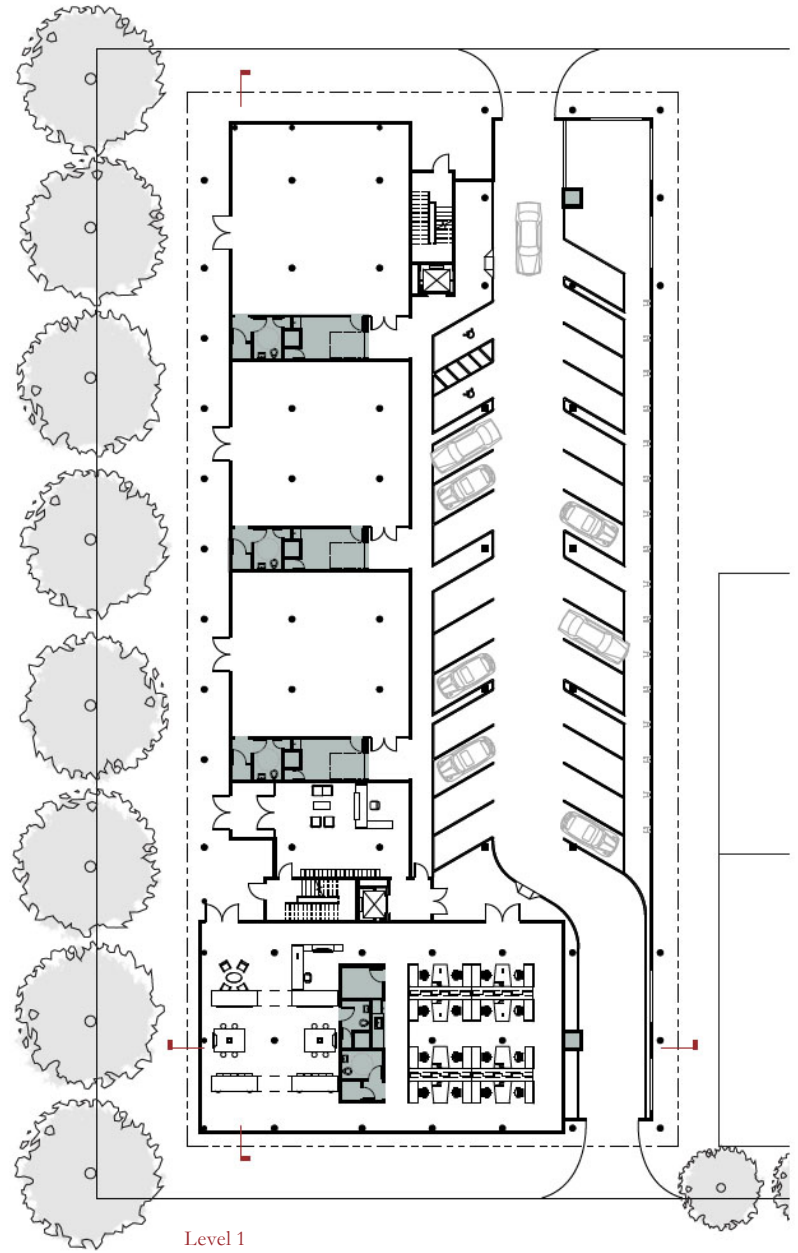
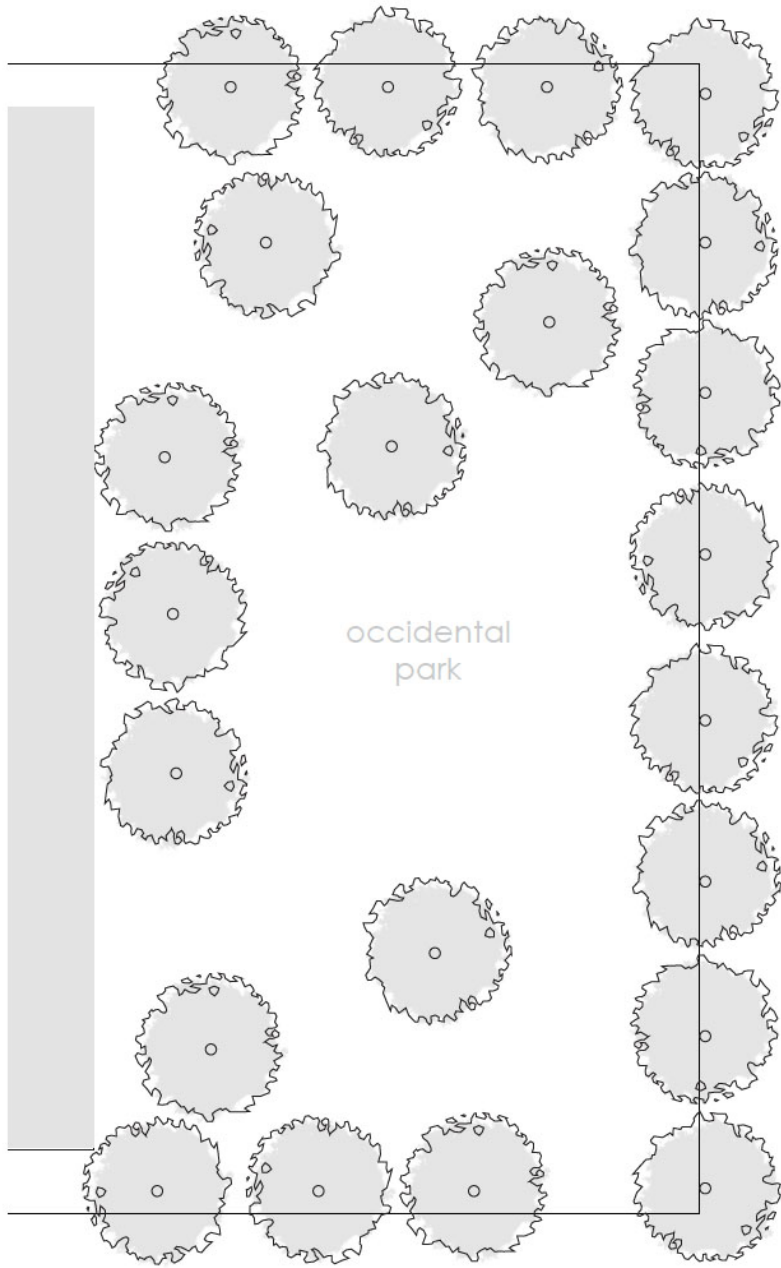

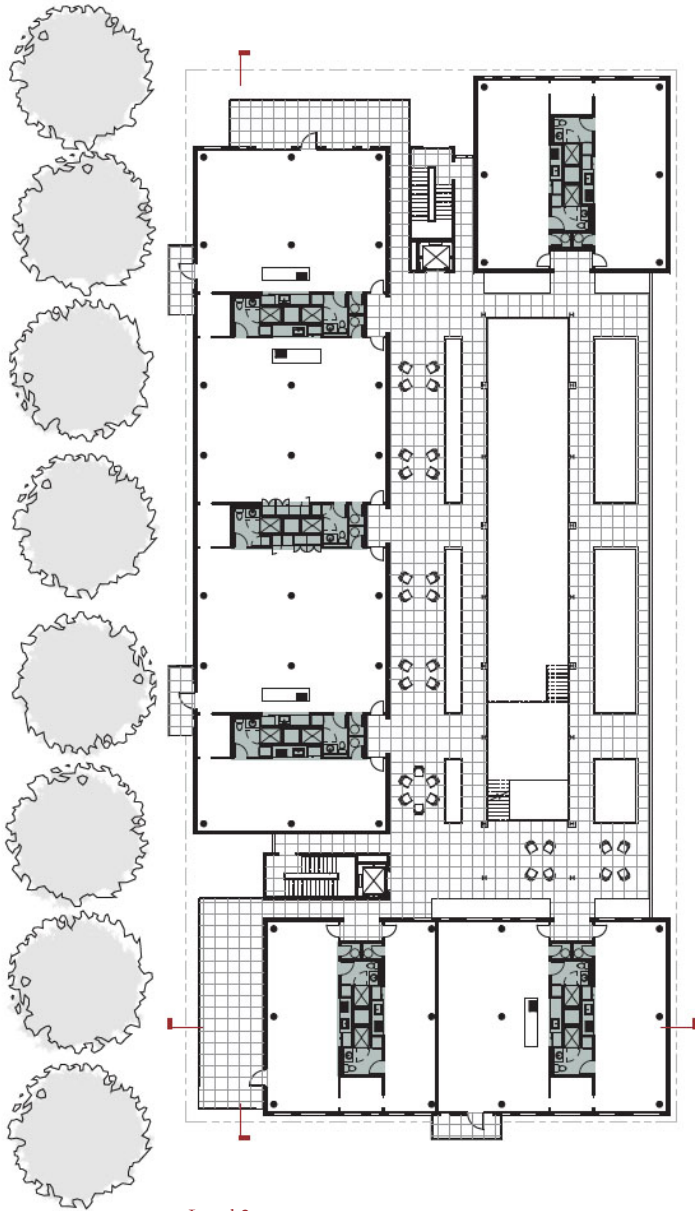

Level 2

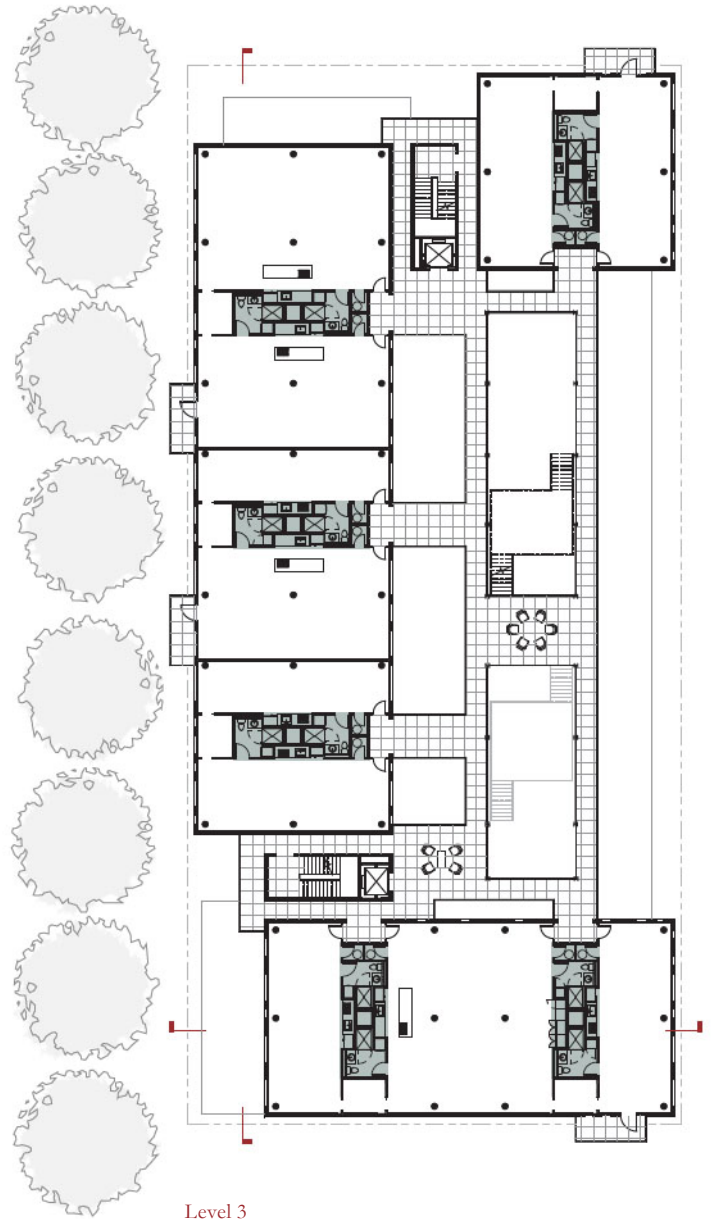

Level 3

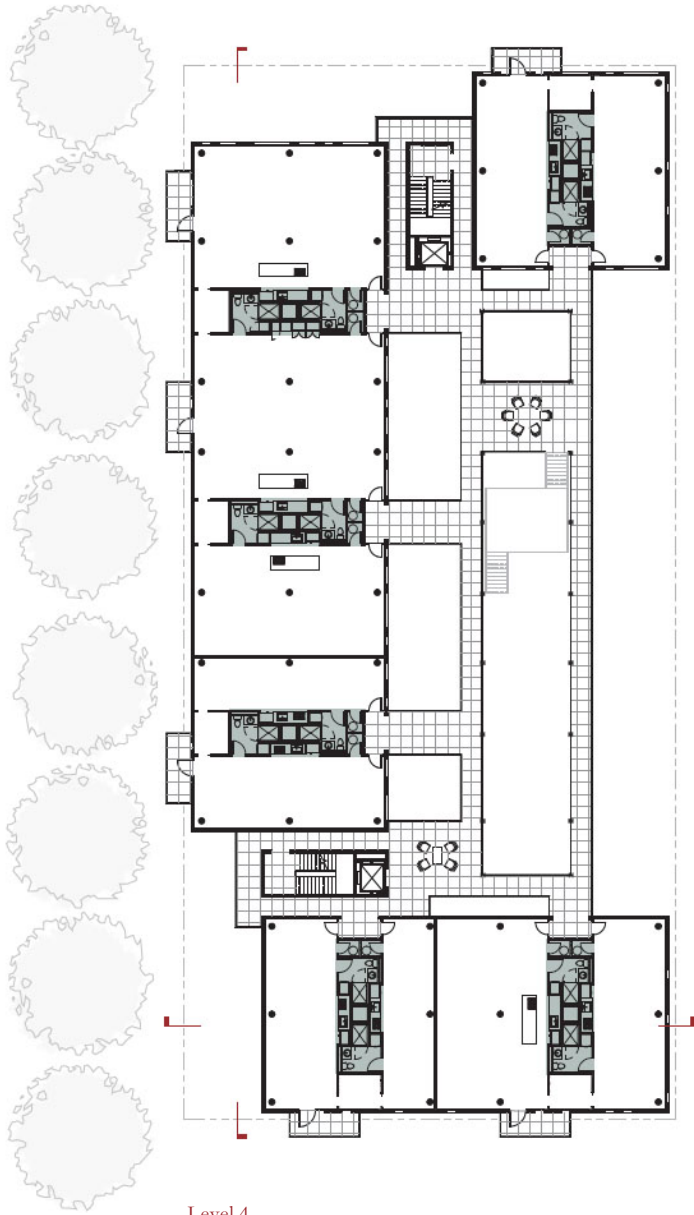

Level 4

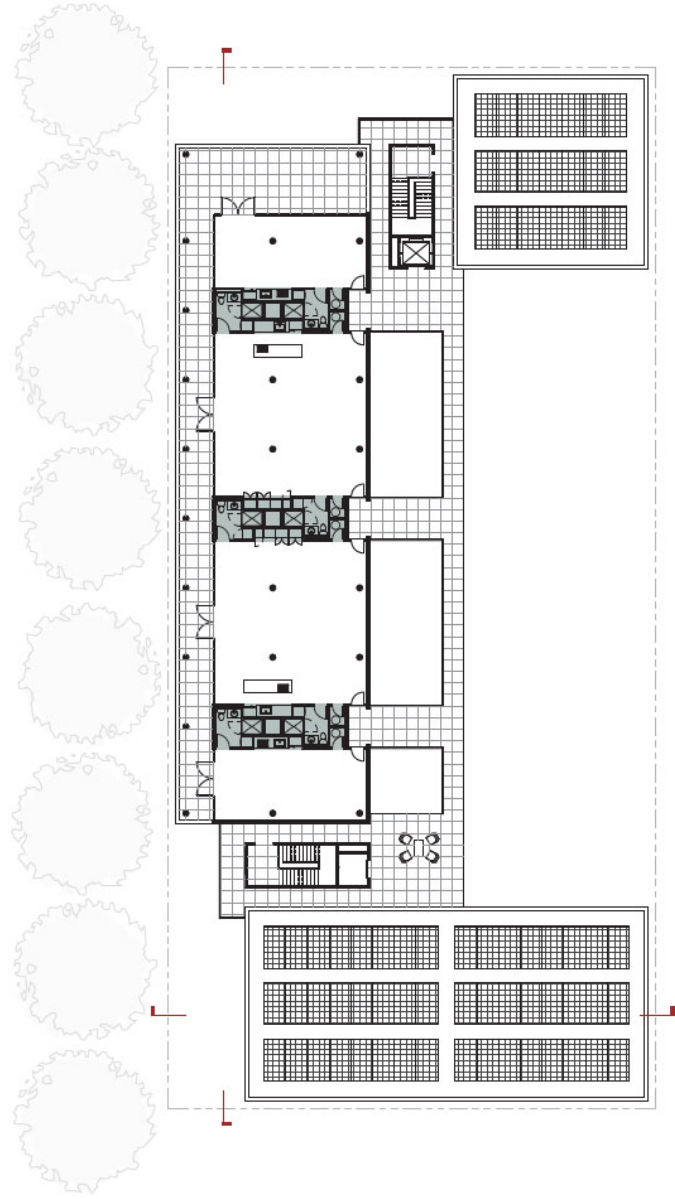

Level 5

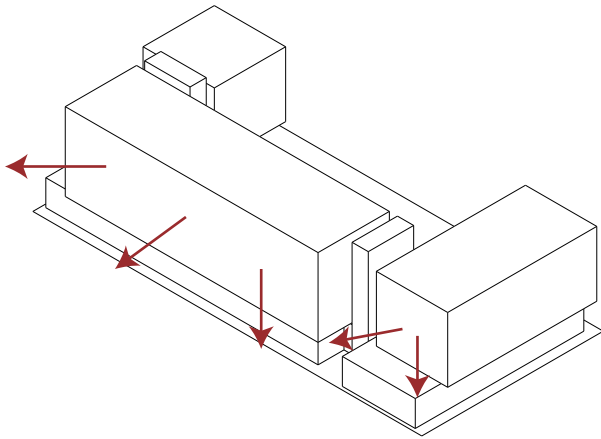

Visual access to park

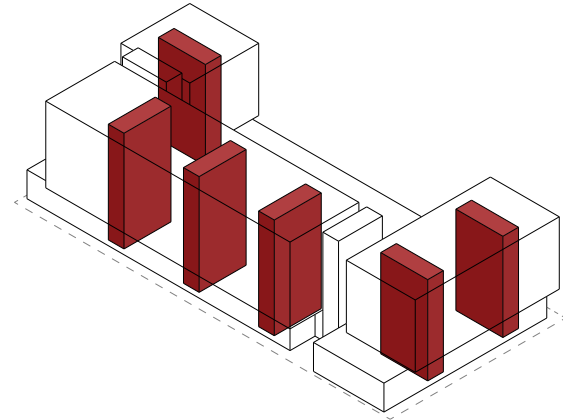

Centralized cores

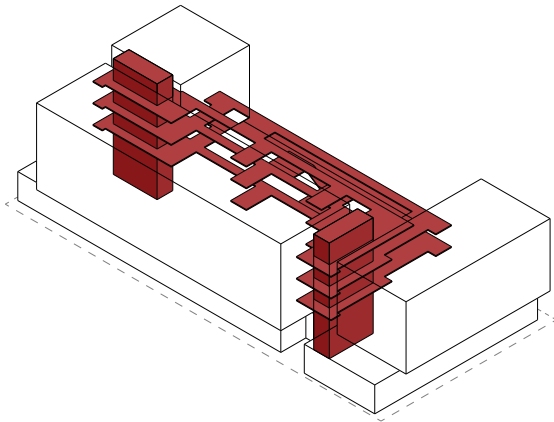

Separate exterior circulation

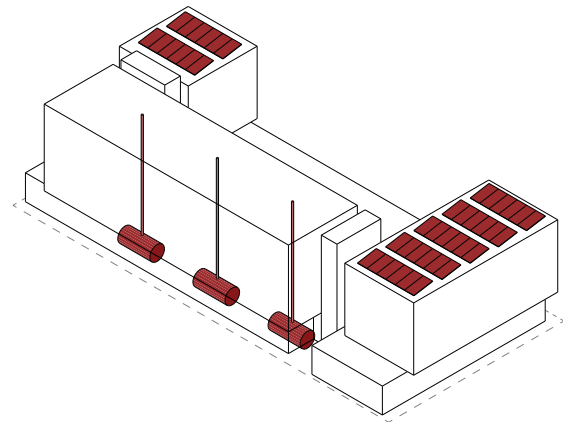

Sustainable measures



Longitudinal Section



West Elevation

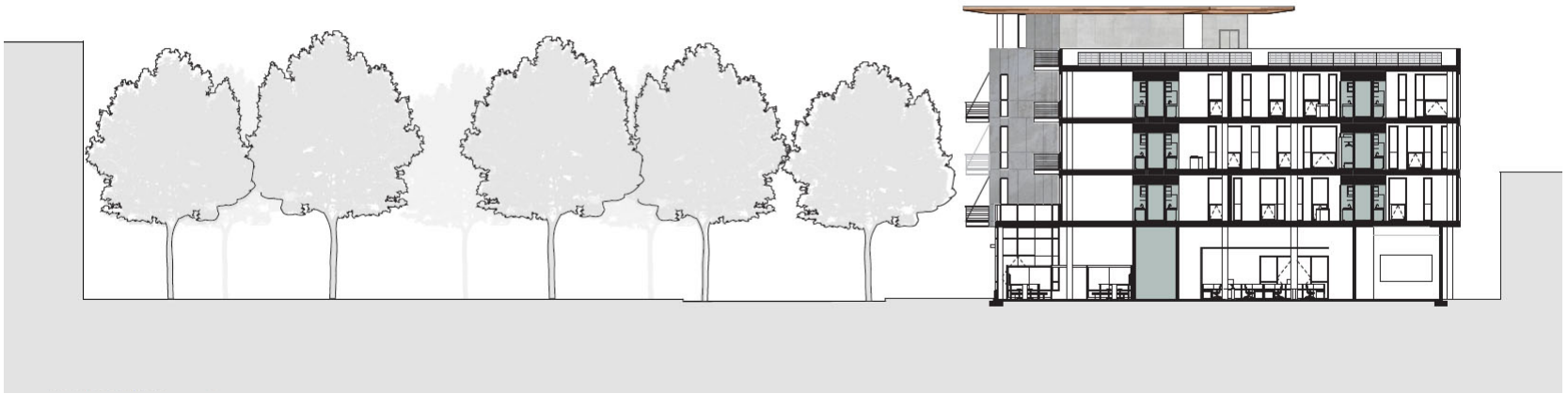

Transverse Section

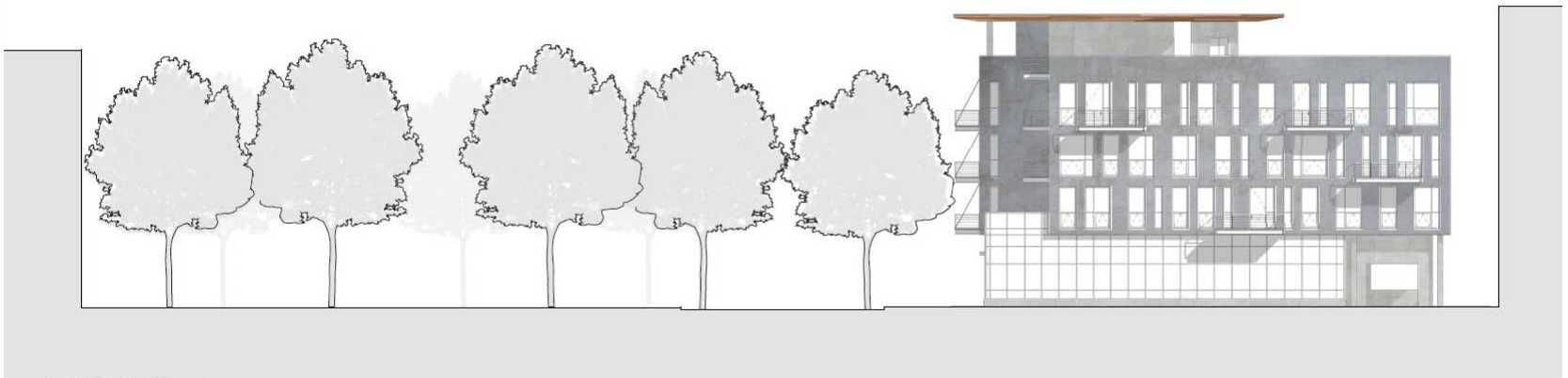

South Elevation

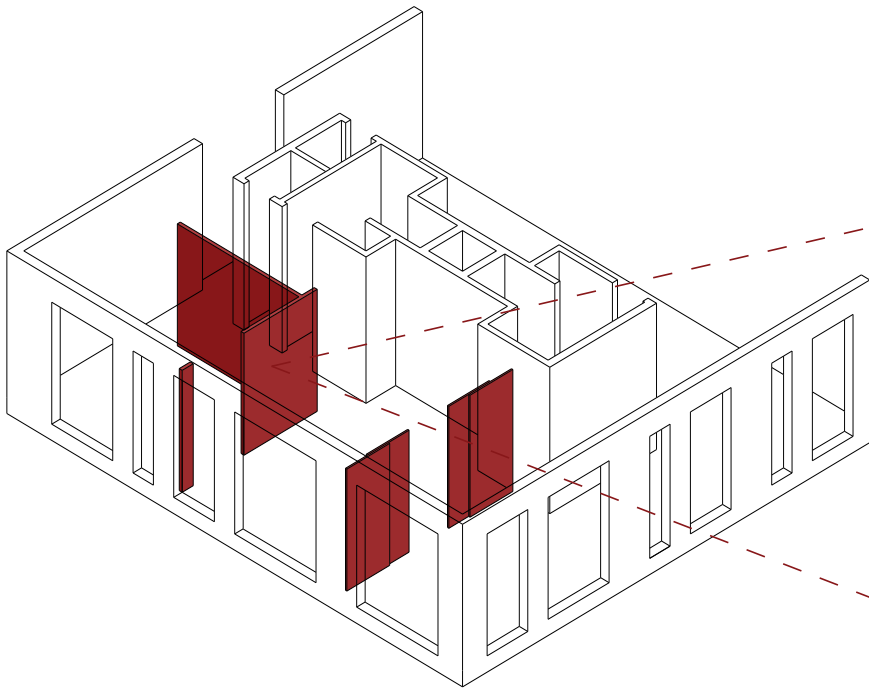

Infill walls

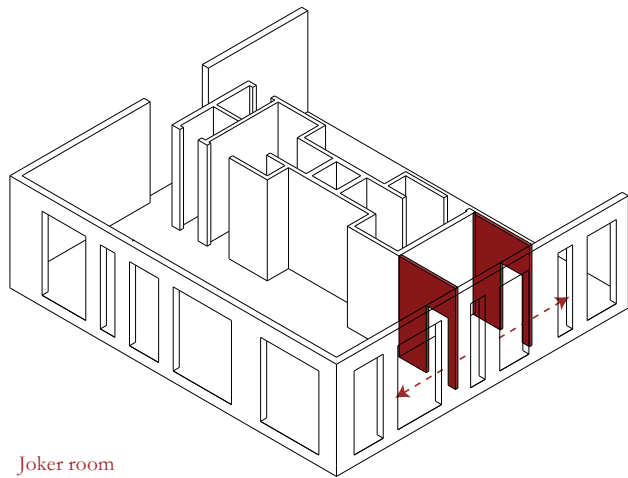
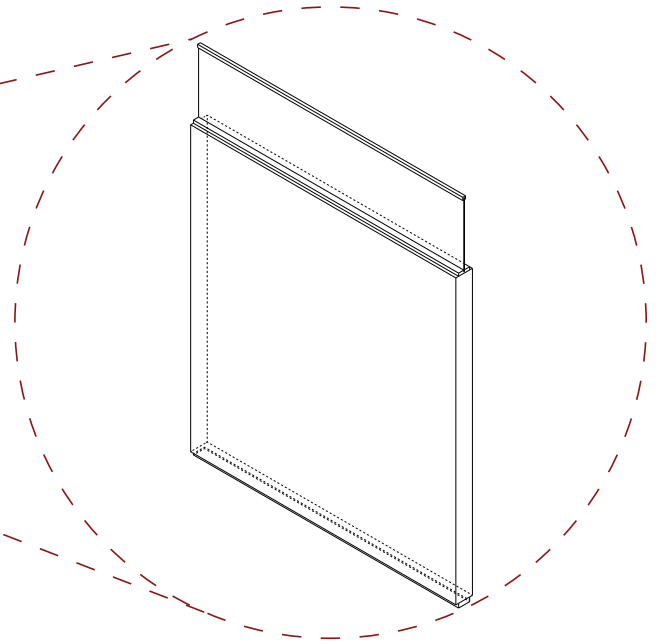

Joker room

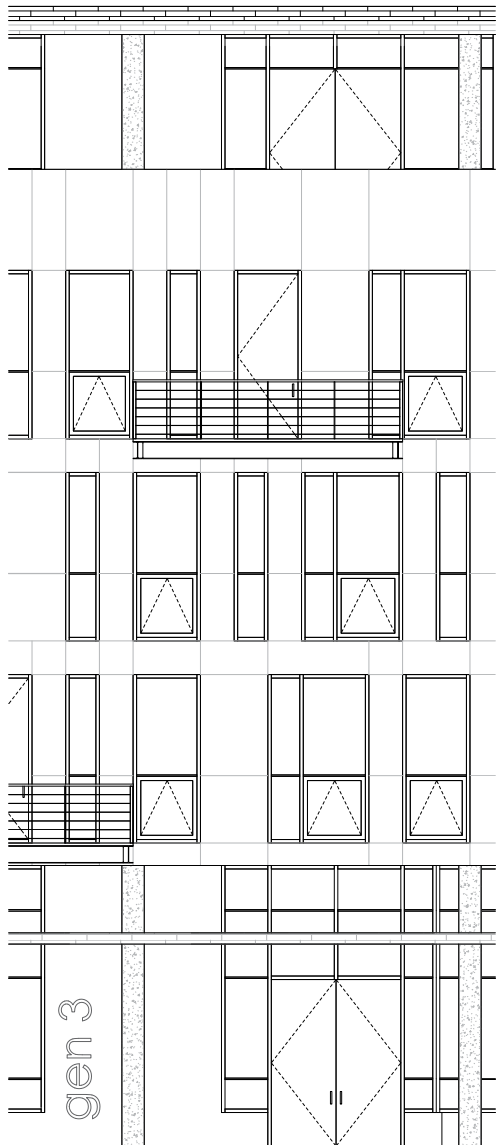

Wall Section/Elevation

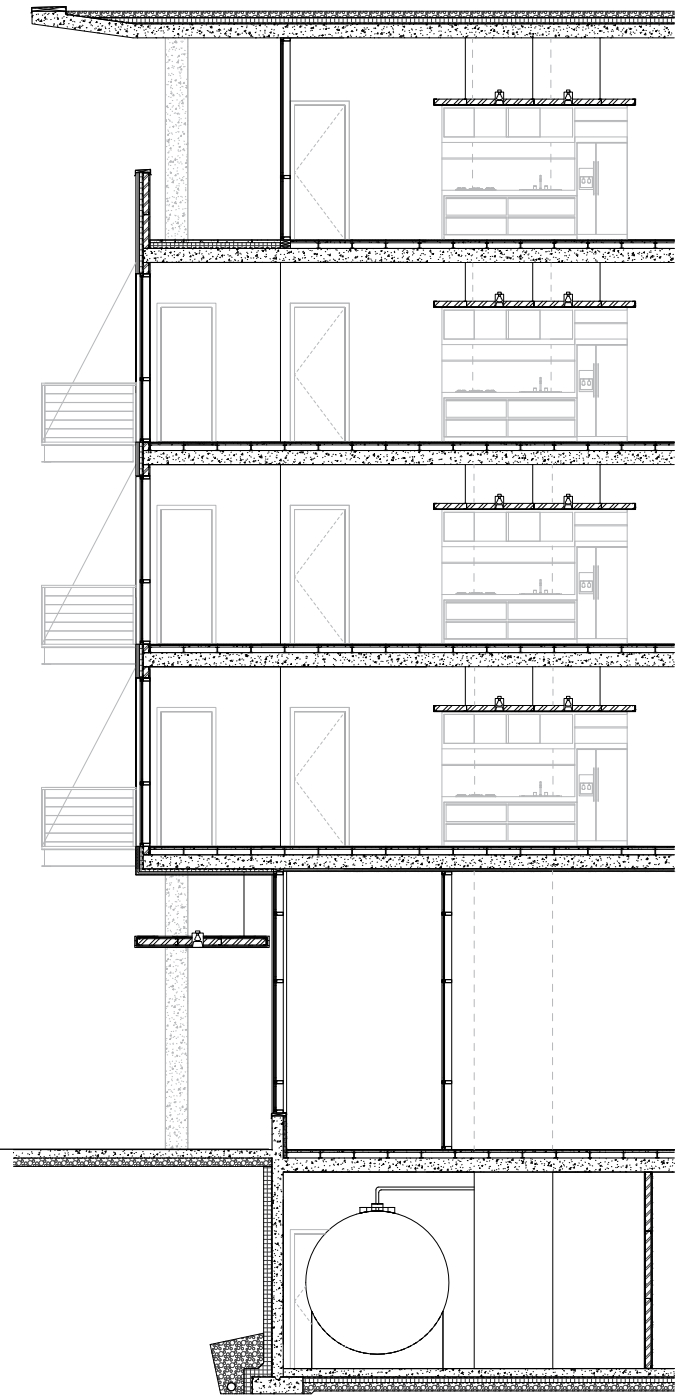

sources

Work Cited

- “Building Livable Communities for Children, Youth, Families and Older Adults.” America’s Best Intergenerational Communities. (2012): 1-15. Web. 5 Feb. 2014. <<http://www.gu.org/LinkClick.aspx?fileticket=VINURofiwk4=&tabid=157&mid=606>>.
- Dey, Andrew. “Reinventing the House: Open Building is a systematic method of efficient, adaptable design and construction, here’s one builder’s approach.” *Fine Homebuilding*. (2006): 58-63 Print.
- Frey, William H. “Baby Boomers and the New Demographics of America’s Seniors.” *Journal of the American Society on Aging*. 34.4 (2010): 28-37. Print.
- Gesler, Wilbert M. *Healing Places*. Lanham Maryland: Rowman & Littlefield Publishers, Inc., 2003. Print.
- Greenblatt, Alan. “Aging Baby Boomers: Will the ‘youth generation’ redefine old age?” *CQ Researcher*. 17.37 (2007): 865-888. Web. 5 Feb. 2014. <http://www.agingociety.org/agingociety/publications/public_policy/cqboomers.pdf>.
- Goyer, Amy. “Multigenerational Living is Rising, and May be to Everyone’s Benefit.” *American Society on Aging. Aging Today*, 11 Jul 2012. Web. 5 Feb 2014. <<http://www.asaging.org/blog/multigenerational-living-rising-and-may-be-everyones-benefit>>.
- Habraken, N.J. *Housing and Settlement Design: The Built Environment and the Limits of Professional Practice*. Cambridge, Massachusetts: Massachusetts Institute of Technology, 1979. Print.
- Kendall, Stephen. “Open Building Concepts.” *CIB W104 Open Building Implementation. International Council for Research and Innovation in Building Construction*, n.d. Web. 29 Jan 2014. <<http://open-building.org/about/objectives.html>>.
- Kendall, Stephen, and Jonathan Teicher. *Residential Open Building*. New York: E&FN Spon, 2000. Print.
- Marcus, Clare Cooper. *House As a Mirror of Self*. Lake Worth, Florida: Nicolas-Hays, Inc, 2006. Print.
- Nascimento, Denise Morado. “N. J. Habraken Explains The Potential Of The Open Building Approach In Architecture Practice.” *Open House International*. 37.4 (2012): 5-13. Print.
- Niederhaus, Sharon G., and John L. Graham. *Together Again: A Creative Guide to Successful Multigenerational Living*. Lanham Maryland: M. Evans, 2007. Print.
- Swensson, Earl. *Hospital and Healthcare Facility Design*. 3rd. New York, NY: W. W. Norton & Company, 2012. Print.
- “Why Population Aging Matters: A Global Perspective.” *Health and Aging. National Institute on Aging*, 07 Oct 2011. Web. 11 Mar 2014. <<http://www.nia.nih.gov/health/publication/why-populationaging-matters-global-perspective/trend-6-changing-family-structure>>.
- Wylde, Margaret, Adrian Robbins-Baron, and Sam Clark. *Building for a Lifetime: The Design and Construction of Fully Accessible Homes*. 1st. Newtown, CT: The Taunton Press, 1994. 209- 232. Print.

Images Cited

Aging person. Digital image. The Jury Expert. The American Society of Trial Consultants, n.d. Web. 17 Apr. 2014. <<http://www.thejuryexpert.com/2012/01/talkin-bout-our-generations-are-we-who-we-wanted-to-be/>>.

Levels of control. Digital image. PS Proefrock Architecture. PS Proefrock, n.d. Web. 17 Apr. 2014. <<https://psproefrock.wordpress.com/page/4/>>

Photo of Stephen Kendall. Digital image. Infill Systems U.S. Stephen Kendall, n.d. Web. 17 Apr. 2014. <<http://infillsystemsus.com/contact>>.

Photo of N. John Habraken. Digital image. All Planned Out?. N. John Habraken, n.d. Web. 17 Apr. 2014. <<http://www.audacity.org/APO-Sp14a.htm>>.

Ruggieri, Alberto. Man hugging house. Digital image. Illustration Source. Illustration Source, n.d. Web. 17 Apr. 2014. <http://www.illustrationsource.com/stock/image/9616/man-hugging-house/?&results_per_page=1&detail=TRUE&page=17>.